

Sound Level Meter 407750



Introduction

Congratulations on your purchase of the Extech 407750 Sound Level Meter. This device measures sound level in dB units with automatic and manual range control. The 407750 also includes selectable frequency weighting ('A' or 'C') and response time (Fast or Slow).

Note that meters with a serial number ending with the letter 'A' meet IEC 61672:2013 Type 2.

This device is shipped with a microphone, wind screen, 9 V battery, user manual, and case.

Careful use of this meter will provide years of reliable service.

Description

Meter Description

1. Microphone
2. Bar graph reading
3. Digital display
4. Control buttons
5. Interface connections

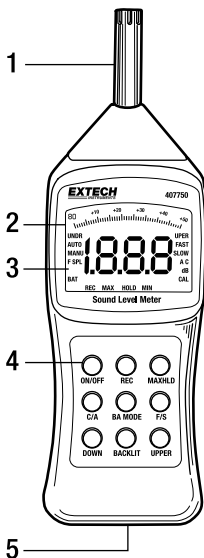

Button Description

ON/OFF	Short press to switch the meter ON or OFF.
REC	Short press to enable the maximum-minimum mode. Press REC to toggle the minimum reading (MIN) and the maximum reading (MAX). Long press this button to exit the mode.
MAXHLD	Short press to freeze/unfreeze the maximum reading on the display (MAX HOLD will appear). The displayed reading will only update when a higher measurement is recorded. Note that the bar graph is unaffected in this mode.
C/A	Short press to select 'A' or 'C' frequency weighting.
BA MODE	The background noise absorber (BA) allows you to monitor the sound level of machinery, even in the presence of high background noise. See the Background Noise Absorber section for instructions on how this button and other buttons are used to accomplish this.
F/S	Short press to select Fast (125 ms) or Slow (1 second) response time.
DOWN	Short press to manually select a lower range. See the Specifications section for available ranges.
BACKLIT	Short press to switch the display backlight ON. It will switch OFF automatically.
UPPER	Short press to manually select a higher range. See the Specifications section for available ranges.

Interface Description

There are 5 jacks at the bottom of the meter. The jacks, from left to right, are described below.

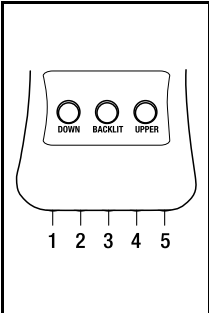
	1	AC adapter. Connect a 9 V adapter (not supplied) to this jack and to an AC source to power the meter.
	2	Calibration adjustment screw. See the Calibration section.
	3	AC analog output jack (3.5 mm). See the Analog Output section.
	4	DC analog output jack (3.5 mm). See the Analog Output section.
	5	RS-232 PC interface jack.

Meter Power

The meter is powered by one 9 V battery, installed in the rear compartment. Refer to the Maintenance section for replacement instructions. The meter can also be powered by an AC adapter (not supplied) that connects to the bottom of the meter (see the Interface Description section for location of jack).

Operation

Quick Start

1. Short press the **ON/OFF** button to switch the meter ON or OFF.
2. When the power-up sequence is complete, position the microphone towards the source of sound. Use the supplied wind screen in breezy conditions.
3. View the measurement reading digitally and on the bar graph.

Display Backlight

Press the **BACKLIT** button to switch the backlight ON. The backlight will switch OFF automatically after approx. 5 seconds.

Automatic and Manual Range

The meter defaults to the automatic range mode ('AUTO' is displayed). In automatic mode, the meter determines the optimum range to provide the highest accuracy.

To control the range manually:

1. Note the two-digit number, to the left of the bar graph; this indicates the low end of the currently selected range.
2. Press the **UPPER** or **DOWN** button to increase or decrease the range. Note the range change on the displayed two-digit number. Refer to the Specifications section for range options. When manually adjusting the range, 'MANU' is displayed.

Frequency Weighting (A and C)

Select 'A' or 'C' weighting by pressing the **C/A** button, the display will indicate the selection.

'A' weighting simulates the frequency response of the human ear. 'A' weighting is used for environmental measurements, OSHA regulatory testing, law enforcement, and workplace design.

'C' weighting provides a flat frequency response. 'C' weighting is typically used to monitor the drone of machinery and appliances, checking for malfunctions.

Response Time (Fast and Slow)

Press the **F/S** button to select Fast (125 ms) or Slow (1 second) response time. The display will indicate the selection.

To capture quick changing sound, select the Fast setting. For sounds that are unchanging, as with the drone of machinery or appliances, select the Slow setting. For hearing conservation, and OSHA related workplace testing, use the Slow response time and 'A' weighting settings.

Maximum (MAX) Hold

Press the **MAXHLD** button to enable the maximum hold function, the display will indicate the mode. The digital display will now only update when a higher reading is detected. The bar graph is unaffected and continues to monitor real time readings. Press the **MAXHLD** button again to exit this mode.

MAX-MIN Record (REC) Mode

Press the **REC** button to start recording the maximum (MAX) and minimum (MIN) measurements. The REC indicator will appear.

In the recording mode, press **REC** to view the minimum reading, the MIN indicator will appear. Press **REC** again to view the

maximum reading, the MAX indicator will appear. Long press **REC** to exit the mode.

Background Noise Absorber (BA) Mode

The **BA** mode allows machine noise to be monitored, even in the presence of high background noise. This is accomplished by storing background noise as a reference and comparing subsequent machine measurements to this reference.

1. Press **ON-OFF** to switch the meter ON.
2. Switch OFF the machine that is to be monitored.
3. Press **MAXHLD** (MAX HOLD appears). See image below.

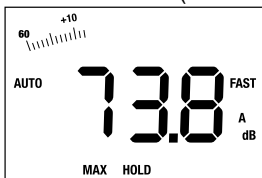

4. Press **BA MODE** ('F' will appear to the left of the 'SPL' icon). The digital display now indicates the background noise (MAX HOLD disappears). See image below.

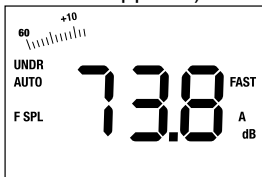

5. Press **MAXHLD** again (MAX HOLD reappears). The meter is now ready to measure actual machine noise. See image below.

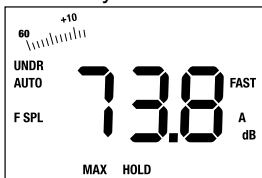

- Switch ON the machine that is to be monitored. The meter reading now represents the actual sound level of the machine under test, with the background noise removed. If there is no change in the reading, the background noise is greater than the sound level of the machine.
- Press **MAXHLD** and then **BA MODE** to exit the BA mode.

Analog Outputs

The meter has an AC and a DC output jack on the bottom of the meter (3.5 mm). Refer to the Interface Description section for jack locations. The output signal amplitude is proportional to the displayed reading, as described below.

DC output = 10 mV per dB

AC output = 0.707 mV RMS (full scale)

To calculate the AC output signal for any given reading, use the formula below.

$0.707 \times 10^{(\text{actual reading} - \text{full scale reading} / 20)}$

Refer to the three examples, below, with the 30 to 80 dB range selected.

80 dB = 0.707 V RMS

70 dB = $0.707 \times 10^{(70 - 80 / 20)} = 0.707 \times 10^{(-0.5)} = 0.223 \text{ V RMS}$

50 dB = $0.707 \times 10^{(50 - 80 / 20)} = 0.707 \times 10^{(-1.5)} = 0.022 \text{ V RMS}$

Calibration

To calibrate the meter, an external calibrator (not supplied) and a small screwdriver are required.

- Set the response to 'Fast'.
- Set the frequency weighting to 'A'.
- Set meter to the 50 ~ 100 dB range.
- Place the calibrator over the microphone.
- Set the calibrator to emit a 1 kHz sine wave tone at 94 dB.
- Adjust the calibration screw on the bottom of the meter to set the displayed reading to 94 dB.

Maintenance

Battery Replacement

When battery voltage is low, the **BAT** alert appears.

1. Remove the rear screw that secures the battery compartment.
2. Remove the old 9 V battery and install a new one, observing correct polarity.
3. Securely replace the battery compartment cover using the compartment screw before use.



Never dispose of used batteries in household waste. Please recycle. **Disposal:** Do not dispose of this instrument in household waste. Please recycle.

Cleaning and Storage

Wipe the meter housing and microphone with a damp cloth (water and mild detergent), as necessary. Do not use solvents or abrasives.

Store the meter with the battery removed.

Specifications

General Specifications

Display	Backlit 1999 digit LCD with bar graph and multifunction icons
Refresh rate	Display digits: 0.5 seconds; Bar graph: 50 ms
Microphone	Electret condenser; 0.5 in. (12.7 mm) diameter
Bar graph resolution	1 dB per step
Frequency bandwidth	31.5 Hz to 8 kHz
Ranges	Six (6) ranges (dB): 30 ~ 80, 40 ~ 90, 50 ~ 100, 60 ~ 110, 70 ~ 120, 80 ~ 130
Resolution	0.1 dB
Accuracy	± 1.0 dB
Response time	Selectable. Fast (125 ms) and Slow (1 second)

Frequency weighting	'A': 30 to 130 dB 'C': 35 to 130 dB
Analog outputs	AC: 0.707 V AC RMS at full scale DC: 10 mV DC per dB
Operating conditions	32 to 122°F (0 to 50°C); < 80% RH
Storage conditions	-4 to 122°F (-20 to 50°C); < 90% RH
Power	9 V battery; 20 hour battery life (typical) BAT appears when battery voltage is low
Dimensions	3.1 x 10.0 x 1.5 in. (80 x 256 x 38 mm)
Weight	8.5 oz. (240 g)
Compliance	Meets IEC 61672:2013 Type 2 (for units with a serial number ending with an 'A')

Frequency Weighting Characteristics

Frequency (Hz)	'A' Weighting (dB)	'C' Weighting (dB)	Tolerance (dB)
31.5	-39.4	-3.0	±3.0
63	-26.2	-0.8	±2.0
125	-16.1	-0.2	±1.5
250	-8.6	0.0	±1.5
500	-3.2	0.0	±1.5
1 k	0.0	0.0	±1.0
2 k	+1.2	-0.2	±2.0
4 k	+1.0	-0.8	±3.0
8 k	-1.1	-3.0	±5.0

Typical A-Weighted Sound Levels (dB)

0	Threshold of hearing
10 ~ 30	Sound studio, whisper (5 ft. [1.5 m])
30 ~ 40	Nighttime residential area
40 ~ 50	Residence, small office
50 ~ 60	Large office or store
60 ~ 70	Speaking (1 ft. [0.3 m])
70 ~ 80	Vacuum cleaner (10 ft. [3 m])
80 ~ 90	Freight train (100 ft. [30 m]), Subway (20 ft. [6.1 m])
90 ~ 100	Boiler room
100 ~ 110	Chain saw
110 ~ 120	Riveting machine
120 ~ 130	Jet takeoff (200 ft. [60 m])
130 ~ 140	50 HP siren (100 ft. [30 m])

Customer Support

Customer Support Local Telephone List:

<https://support.flir.com/contact>

Returns (RMA):

<https://customer.flir.com/Home>

Warranty

Teledyne FLIR warrants this Extech brand instrument to be free of defects in parts and workmanship for two years from date of shipment. To view the full warranty text, please visit the support site, link below.

<https://www.flir.com/support-center/warranty/>

Website

<http://www.flir.com>

Customer support

<http://support.flir.com>

Copyright

© 2026, FLIR Systems, Inc. All rights reserved worldwide.

Disclaimer

Specifications subject to change without further notice. Models and accessories subject to regional market considerations. License procedures may apply. Products described herein may be subject to US Export Regulations. Please refer to exportquestions@flir.com with any questions.

Publ. No.: NAS100311
Release: AA
Commit: 111554
Head: 111554
Language: en-US
Modified: 2026-04-15
Formatted: 2026-04-15

